

Educator Guide

This guide serves as an introduction to the Design your own Pen Holder Challenge. Using the Engineering Design Process, the students will research, design, 3D model, build, test, and improve their pen holders. If time is a constraint, you may omit the prototype portion.

Supplies:

- Ruler (in inches)
- Pencil, paper
- Laptop per student
- *Recycled supplies for prototyping (optional)*



Tinkercad is the recommended 3D modeling software to use with students in grades 3 to 12. As an educator, when you sign up for a Tinkercad account, you can choose to create a Classroom to manage your students' accounts and view their designs. Click on **Classes** and select **Create new class**.

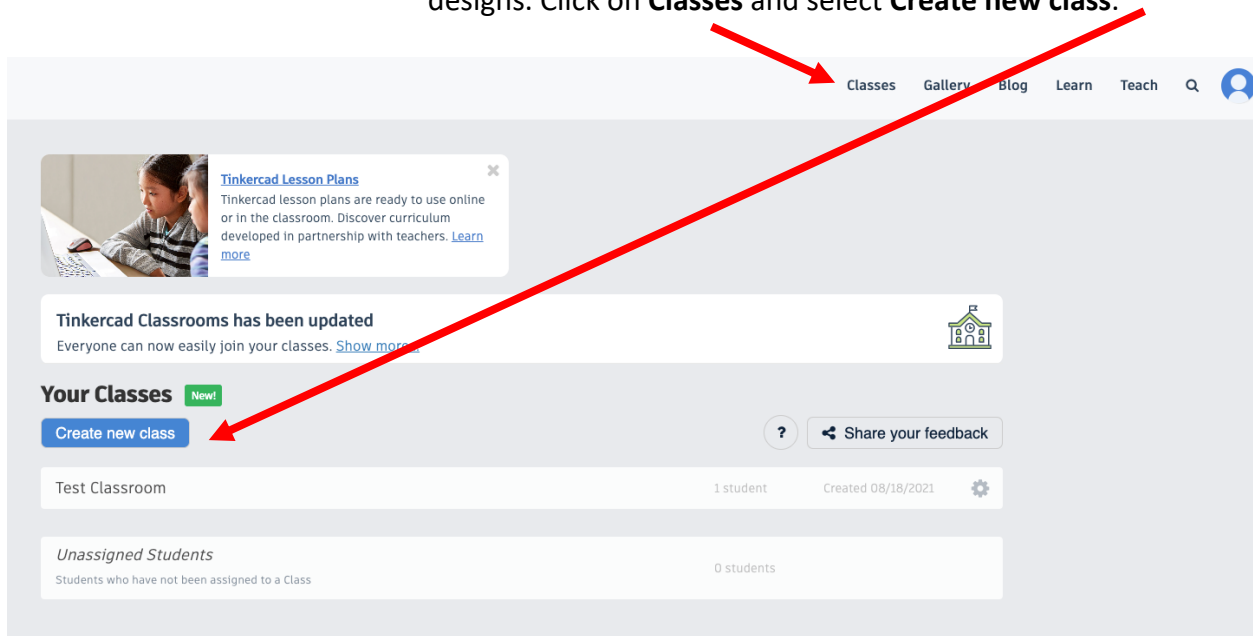

The supplemental Google Slides is used for the students to document their Engineering Design Process. You may use these Slides as a template to start the process with your students, and can add more information for the students as you see fit.

As part of a Summative Assessment, the Google Slides can be used as part of a student's presentation of their designed pen holder.

Engineering Design Process – the iterative cyclical process engineers use to design, create, build, test, and improve their innovations

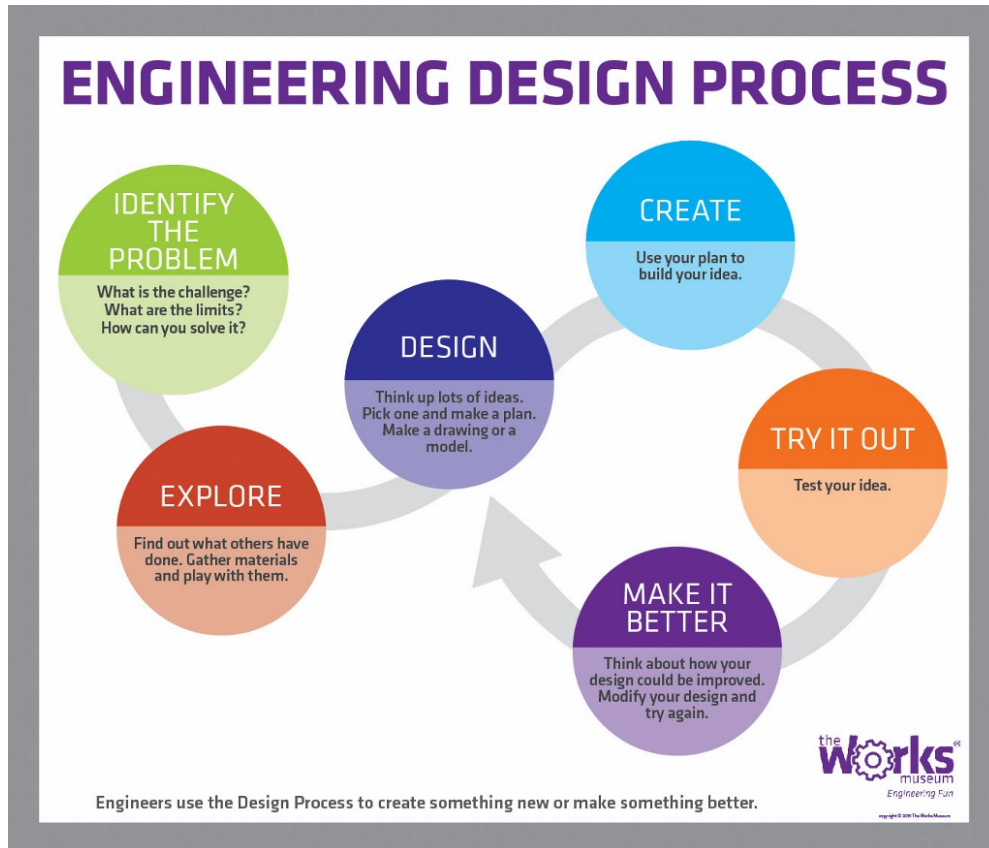

<https://theworks.org/educators-and-groups/elementary-engineering-resources/engineering-design-process/>

Identify the Problem

Writing a Problem Statement

- Clear and Concise
- Shouldn't be a question
- Shouldn't give a potential solution
- Think about what is the purpose of having a pen holder?
- Do you currently have a pen holder and what would you do to make it better?

Examples:

I will create a pen holder to help organize pens on my desk.
I will create a pen holder to keep my pens in one place.

Non-Examples:

I will create a pen holder on TinkerCAD.
I will create a pen holder that can hold 10 pens and pencils, a pair of scissors, and have an additional phone stand.

Setting Criteria

- Guidelines to follow when designing
- What do you want your pen holder to carry?
- Might help to do a bit of research first

Examples:

Can hold at least 5 pens and pencils
Include a built-in ruler or space to hold ruler for easy measuring
Include phone stand with space to fit charging cable

Constraints

- Limits on the design and challenges

Examples:

Size limit
Amount of material used

Student Assessment

Refer to Google Slides

Explore

Research other pen holders online.

Recommend looking at Amazon or Etsy for ideas on pen holders

What are some aspects that you like about certain pen holders? You shouldn't be copying exactly another pen holder, but rather taking the best ideas from each and making your own.

Student Assessment

Research and choose 3-5 pen holder designs

Refer to Google Slides

Design

Using the pen holder ideas that you researched, take your favorite parts of each and sketch a drawing of your own design.

Also include Top, Front, Side views and labels of your design. Include dimensions (in inches)

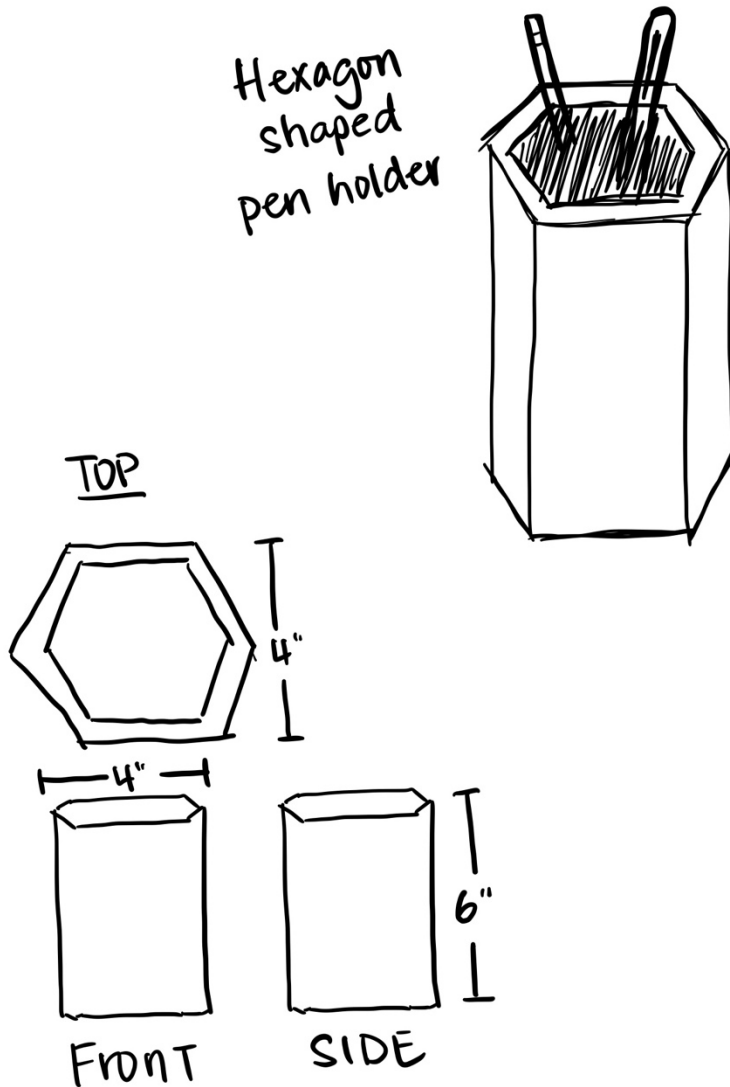

Student Assessment

Refer to Google Slides

Create

Prototype

Using recycled materials (cardboard, paper, Styrofoam, paper plates, cups), build a working prototype of your pen holder.

Try to keep it to the exact dimensions (in inches) to get the most accurate representation of your designed pen holder.

Students can take a picture and upload their prototype image to the Google Slides.



TinkerCAD model

Make sure each student has their own TinkerCAD login whether using a TinkerCAD classroom or their personal email login.

If brand new to TinkerCAD, click **Learn** at the top, recommend that each student goes through the **Starters** tutorial and chooses 1 or 2 **Lessons** to complete.

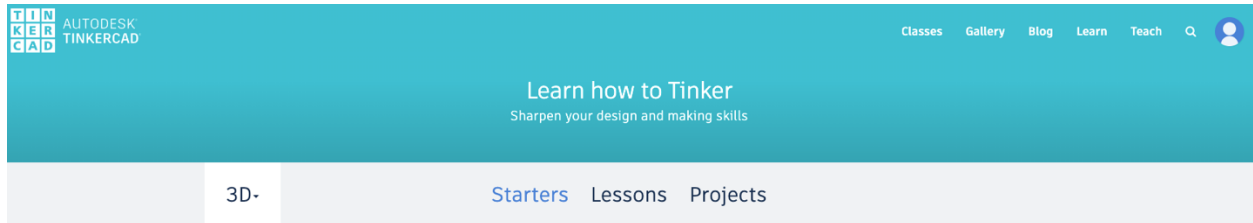

Starters define basic 3D design functions, and link to relevant Lessons to develop your skills.

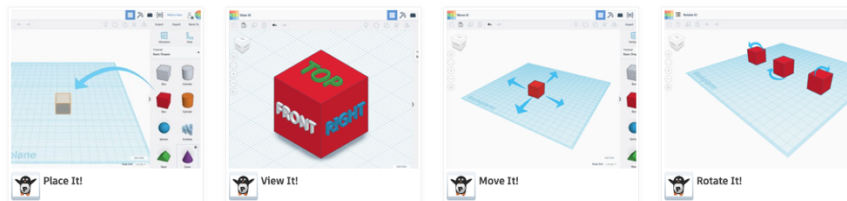

[See all Starters](#)

Pen Holder Design Challenge 2021

When students are ready to design their own pen holder, make sure they set up their Workspace correctly:

Convert to right units

Create a new design

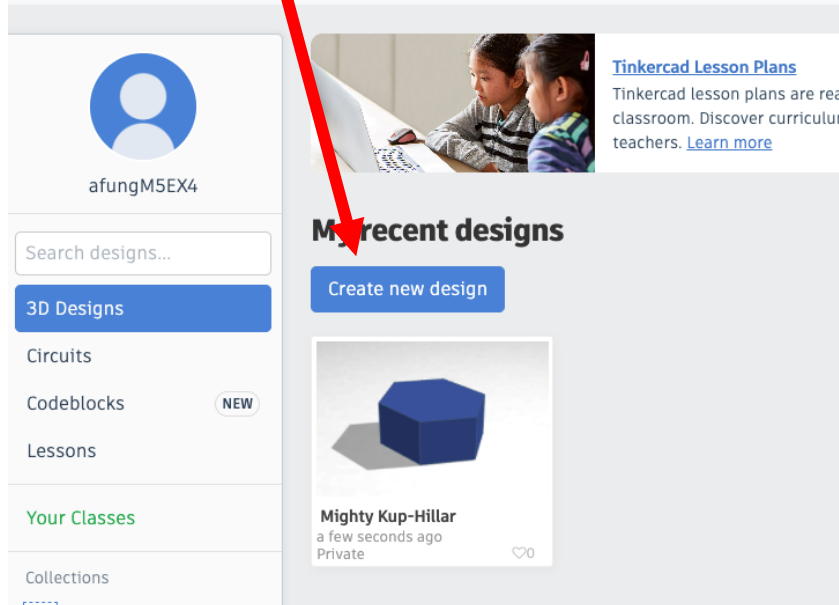

Click on Edit Grid

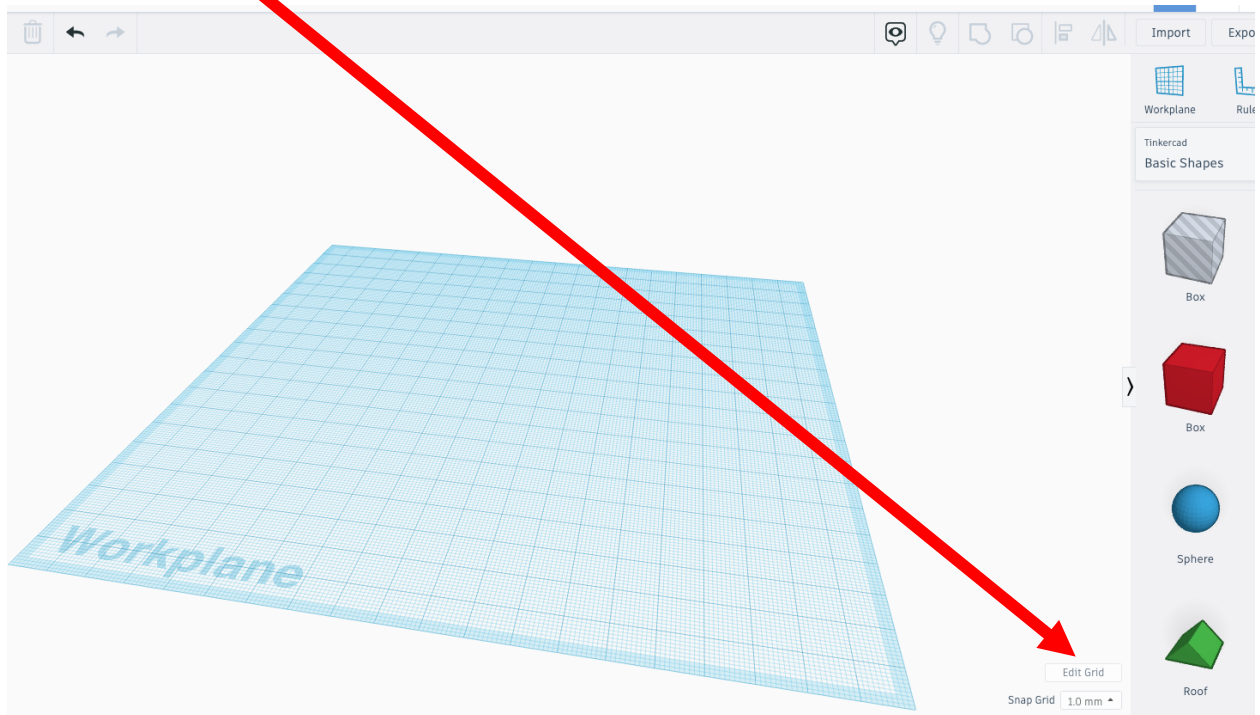

Pen Holder Design Challenge 2021

Update from millimeters to **INCHES**

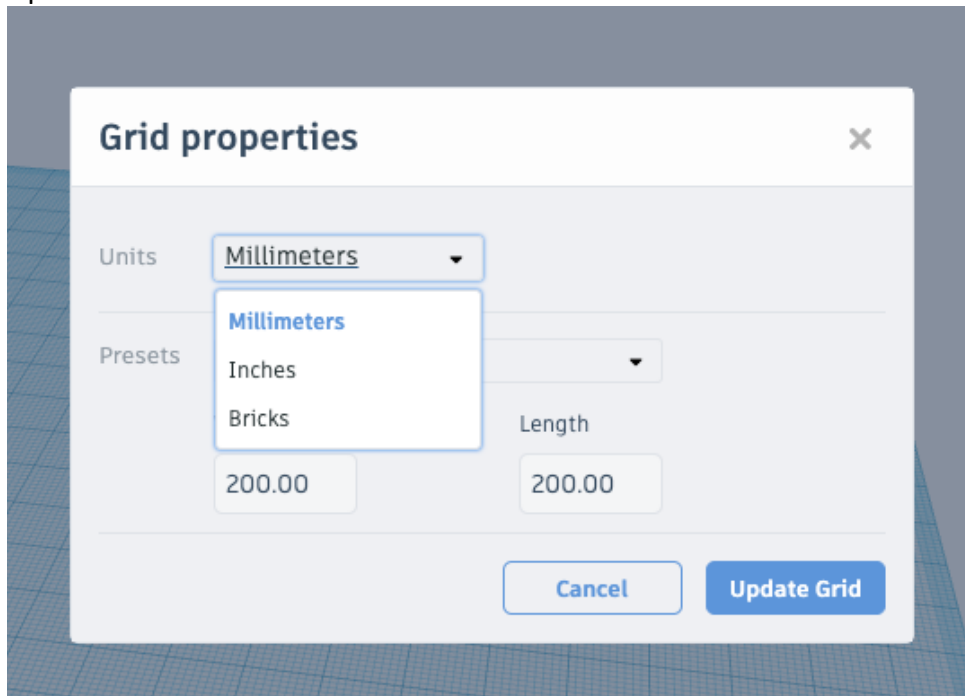

Click **Update Grid**

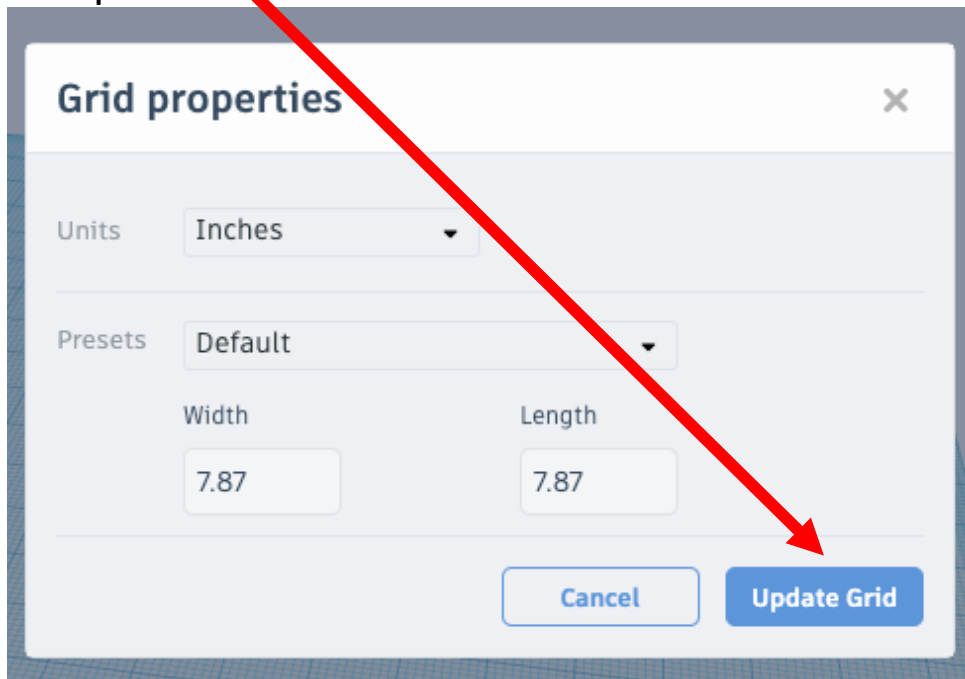

Now, you can begin creating your pen holder!
Be sure to size your pen holder correctly. Use a ruler (with inches) as your reference!

TinkerCAD Tips!

- Students should utilize the **Hole** tool to create holes for their pen holder
- Students should **group** their design together so it is one solid object with no floating shapes or moving objects
- Students should make sure the design is on the **Workplane**. To check, click on the design, drag the black triangle at the top up and down until you see the number "0" at the bottom of the workplane.

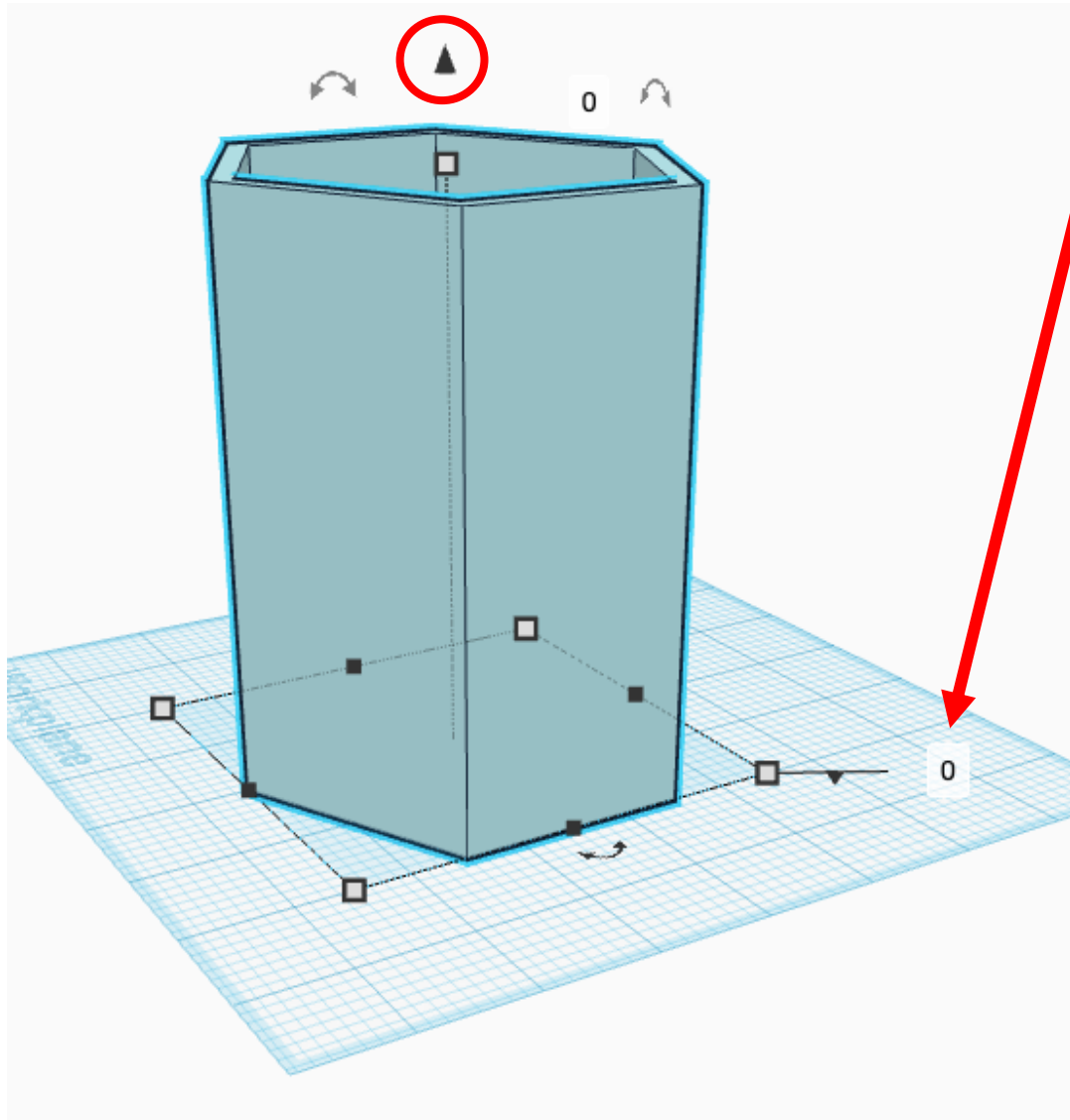

Pen Holder Design Challenge 2021

Taking an image of your design

Rotate your design to get the best view. Use the View Cube or Right Click + drag

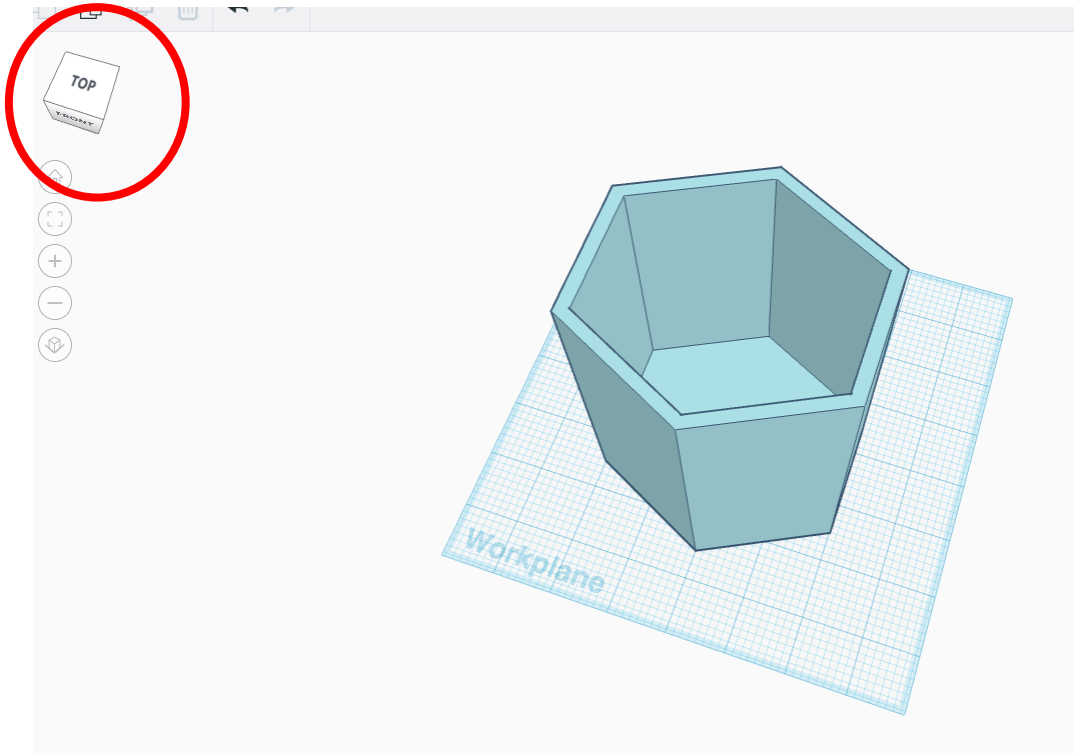

Once you've found the best view, click **Send To**

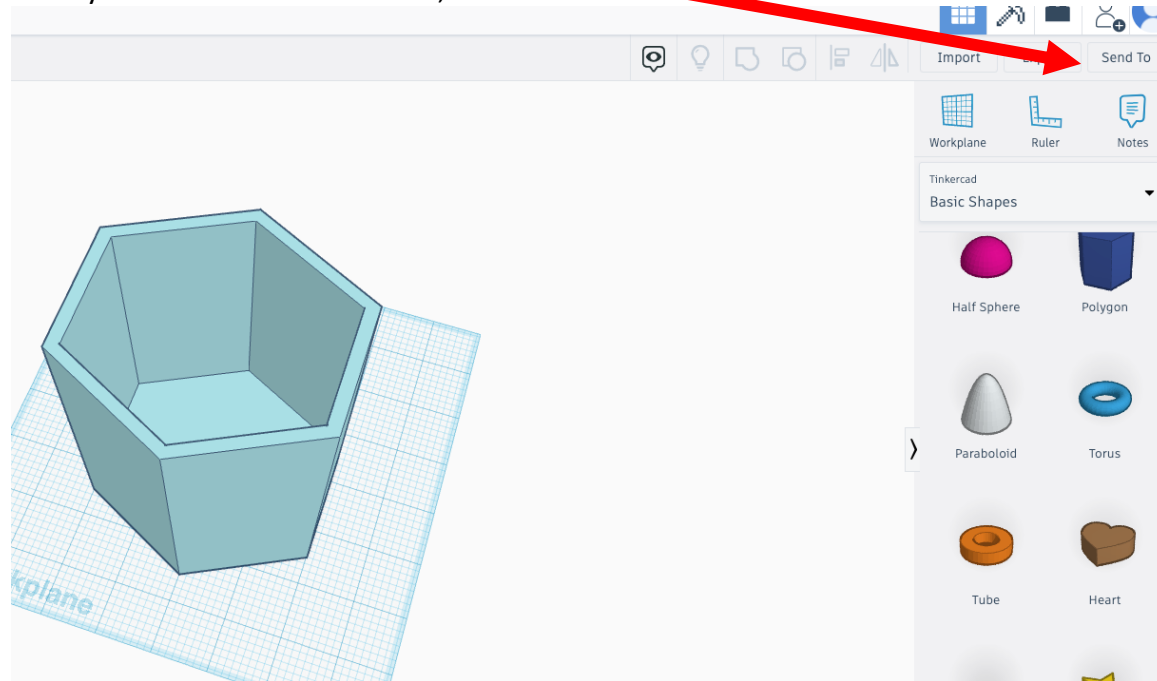

Pen Holder Design Challenge 2021

Click the Down Arrow to download your image to your computer

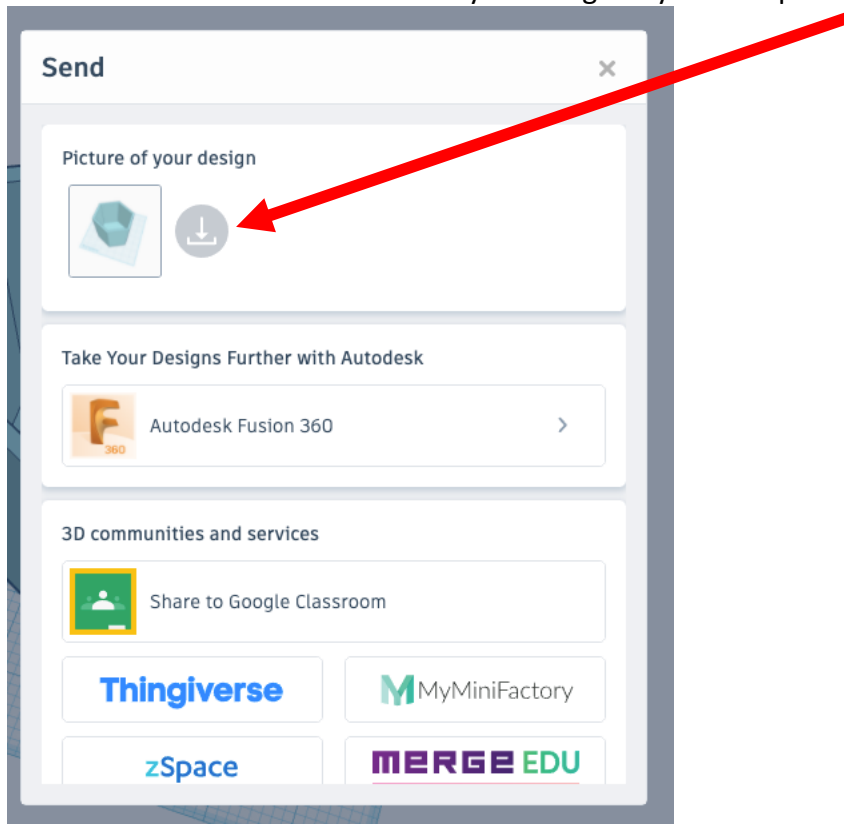

Students can attach their image or screenshot to the Google Slides.

Try it Out

Self-Assessment

Let student try out his/her own pen holder and see if it's to their liking.

Authentic Feedback

Allow students to critique each other's and suggest improvements for their pen holder design.

You could have each student do a mini presentation showing their prototype and the TinkerCAD model and allow the other students to share what they liked or could improve on.

Another way is to share the designs on a photo sharing app, like Flipgrid, that allows students to comment on each other's designs.

Student Assessment

Have students list out at least 3 pros and 3 cons of their pen holder design.

Write it out on the Google Slides

Make it Better

If time allows, let the students go through the Design and Create steps of the Engineering Design Process to better improve their design.

You could have the students continue to document their design iteration on the Google Slides. However, it is up to you to decide the timeline of the completion of the project.

Student Assessment

Refer to Google Slides